

A detailed technical illustration of a plain bearing assembly, specifically Type Z. The drawing shows a cross-section of the bearing housing and the bearing itself. The bearing is a cylindrical component with a central bore, mounted within a housing. The housing has a flange with several bolt holes. The bearing has a textured outer surface, possibly indicating a specific material or finish. The illustration is rendered in a blue and white color scheme with fine lines and shading to show the mechanical details.

**PLAIN BEARINGS  
TYPE Z**

**ZOLLERN**

**PLAIN BEARING TECHNOLOGY**

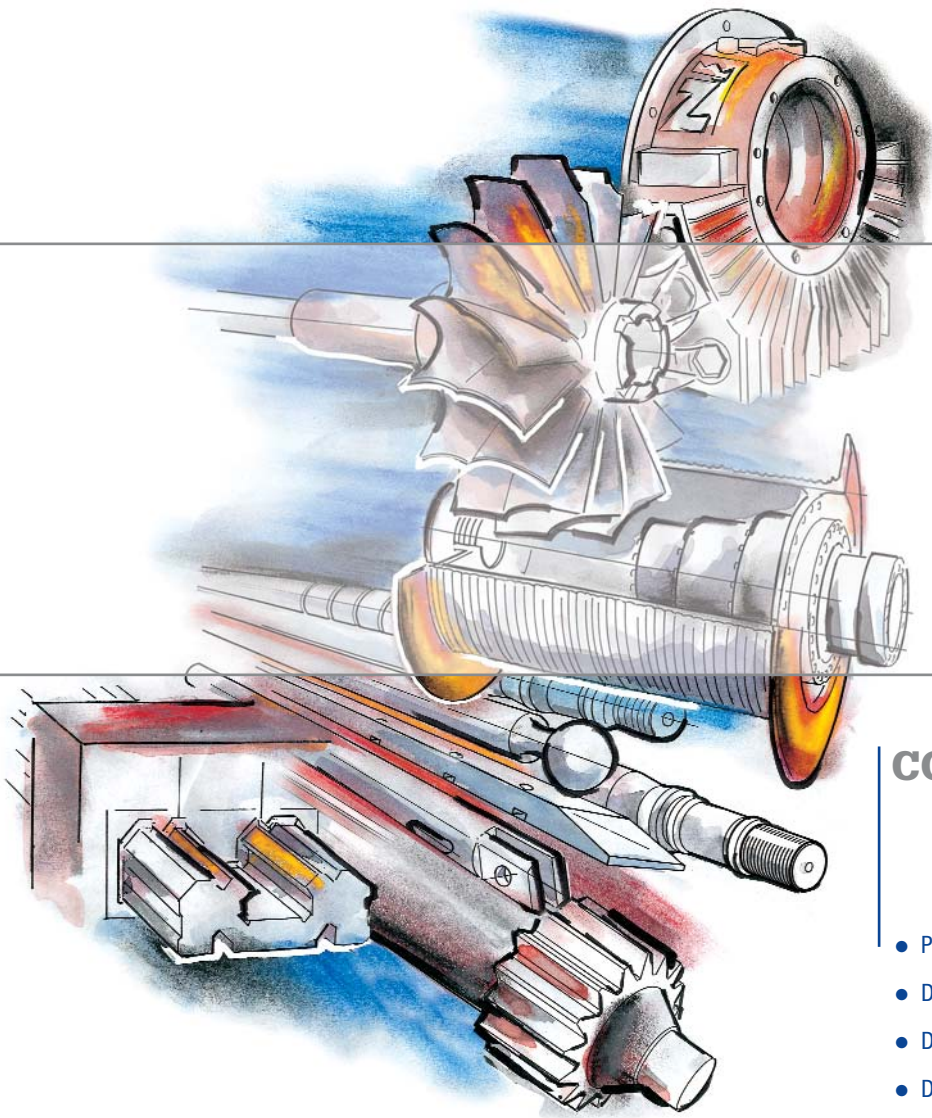

## The ZOLLERN Group

ZOLLERN GmbH & Co. KG is a company with world wide operations, employing over 3000 employees in the business fields of transmission technology (automation, gear boxes and winches), plain bearing technology, machine components, foundry technology and steel profiles.

## CONTENT

● Plain bearings type Z	3
● Description of the design	4
● Dimensions ZR	6
● Dimensions of shaft ZR	8
● Dimensions of seals ZR/ZF/ZM	9
● Dimensions ZF	10
● Dimensions of shaft ZF	12
● Machine seals ZF	13
● Dimensions ZM	14
● Dimensions of shaft ZM	16
● Dimensions ZR/ZF/ZM Version Z...A	17

# PLAIN BEARINGS TYPE Z

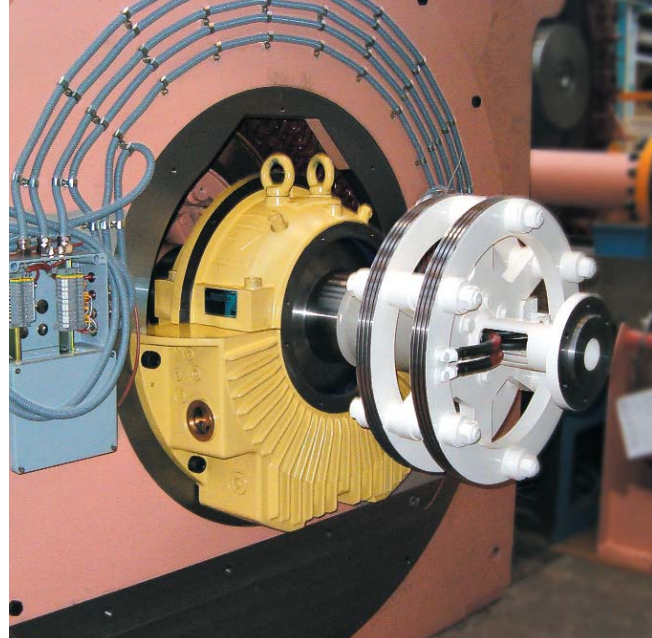

## Nomination of bearings



The nomination of the different bearings is acc. to the following table:

### 1 Type Z

### 2 Type of housing

- R pedestal bearing, finned
- G pedestal bearing, smooth
- F end flange mounted bearing, finned
- M centre flange mounted bearing, finned

### 3 Heat dissipation

- N natural cooled by convection
- Z lubrication by oil circulation with external oil cooling
- X lubrication by oil circulation with external oil cooling for high oil throughput
- W finned water cooler in the oil sump
- U recirculating oil pump and natural cooling
- T recirculating oil pump and water cooler in the oil sump

### 4 Shape of bore and type of lubrication

- C plain cylindrical bore without oil ring
- L plain cylindrical bore with loose oil ring
- F plain cylindrical bore with oil disk
- Y two-lobe bore without oil ring
- V four-lobe bore without oil ring
- K journal tilting pads without oil ring

### 5 Geometry of thrust bearing

- Q without thrust capability
- B plain white metal lined shoulders with oil grooves
- K tapered land thrust faces for both sense of rotation
- D tapered land thrust faces for one sense of rotation
- A round tilting thrust pads, cup spring supported

### 6 Size

### 7 Shaft diameter

## Example for the nomination of a complete bearing

### Z M N L B 11-125

ZOLLERN centre flange mounted, finned bearing, natural cooled by convection, plain cylindrical bore with loose oil ring, plain white metal lined shoulders with oil grooves (locating or non-locating bearing), size 11, for shaft diameter 125 mm.

## DESCRIPTION OF THE DESIGN



The Zollern Z type of horizontal bearings are designed according to different DIN and ISO specifications for a wide range of heavy duty applications (electrical machines, fans and blowers, turbines and test rigs). The modular system applies for the different types of bearings (pedestal, end flange and centre flange), i.e. the combination of different modules of this modular system is always possible. This has resulted in simple assembly and elimination of mistakes during installation, commissioning and maintenance procedures due to the positioning of screws and pins.

### Housing

The bearing housings are finned and manufactured from nodular cast iron GGG 40 giving high strength and best heat dissipation. The spherical seat in the housing ensures easy alignment during assembly and the loads are steady induced to the lower part of the housing. Therefore these bearings are designed for highest stress. Thread holes for the fitting of thermosensors in the journal bush and oilsump as well as for oil inlet and outlet pipes are provided on both sides of the housings as a standard. Water cooling tubes and vibration probes can be easily fitted by small amendments of the housings.

### Bearing shells

The shell is supplied in halves and spherically seated in the housing ensuring easy alignment during assembly. The material is low carbon steel lined with high tin based white metal. This construction allows easy assembly and long life cycle. Bearing shells with plain cylindrical bore and loose oil ring are used in most cases, but other shapes of bore are possible. Optional water coolers are available and the bearing can be connected to an oil circulation. Where the specific load on start-up is too high, or for slow speed applications a hydrostatic jacking system can be incorporated. Zollern will give recommendations for the oil supply pressure and the required flow rate. Bearing shells without thrust capability, or with plain white metal lined shoulders (small, temporary thrust loads) with oil grooves, or taper land faces (medium thrust loads) for one or both sense of rotation can be selected depending on the level of the thrust load. The bearing shells are equipped with tilting thrust pads for highest thrust loads.



### Oil supply

Fully self contained lubrication is achieved from a loose oil ring. Alternatively, where bearings are lubricated by an external oil circulation system, this loose oil ring can be used to permit emergency shutdown without damage if a system failure occurs. Z-bearings can be used for marine applications by using an oil ring guide to cater for vessel motions.

### Sealing

The seals are selected for the different operation conditions and for the requested protection level. The standard arrangement is the floating labyrinth seal (IP 44) made of high heat resistant, fibre-reinforced synthetic material. Bearings for high oil throughput are equipped with adjustable rigid seals (IP 44) made of aluminium alloy. Both types of seals can be equipped with bolt-on baffles (IP 55) or dust flingers (IP 54) if the bearing is operating in a dusty or a wet environment or if rotating parts (clutches, couplings, fans etc.) are fitted close to the bearing. Special seals offering higher protection, or pressurized seals etc. can be supplied for special applications. Details upon request. An end cover is used while the end of the shaft is inside the bearing.

### Electrical insulation

To prevent stray currents conducted by the shaft Z-bearings can be supplied electrically insulated as an option. In this case the spherical seat of the housing is coated with a wear-resistant and temperature-resistant synthetic material.

### Selection of oil

It is recommended that any branded mineral oil (preferably inhibited against foaming, ageing and oxidation) is used as the lubricant. The viscosity for every application is selected by the Zollern bearing design computer program. The output resulting is provided with every quotation.

### Temperature control

Provisions for the fitting of thermosensors in the journal bush and oil sump are provided as standard. Which type of sensor is used depends on the type of reading (direct reading, centralized control system, recording instrument). It is possible to fit two different and independant thermosensors.

# DIMENSIONS ZR

Size	D (H7)	B	b <sub>1</sub>	b <sub>2</sub>	b <sub>3</sub>	b <sub>13</sub>	d <sub>1</sub> /d <sub>2</sub> (optional)	d <sub>3</sub>	d <sub>5</sub>	d <sub>7</sub>	d <sub>8</sub>	d <sub>9</sub>	d <sub>10</sub>	d <sub>11</sub>	d <sub>12</sub>	d <sub>13</sub>	d <sub>14</sub>	d <sub>15</sub>	d <sub>17</sub> <sup>1)</sup>
9	80	61,4	80	194	150	104	80/ 90	160	G 3/8	G 1 1/4	G 1/2	11	8xM6	86	110	180	200	22	10,4
	90	61,4					96							120					
	100	65					106							130					
11	100	81,4	100	214	170	122	100/110	190	G 3/8	G 1 1/2	G 1/2	11	8xM6	108	135	210	230	26	10,4
	110	81,4					118							150					
	125	85					133							160					
14	125	105,4	125	259	215	158	125/140	240	G 1/2	G 2	G 1/2	11	8xM6	135	170	260	280	30	10,4
	140	105,4					150							190					
	160	106,4					170							200					
	180	106,4					190							220					
18	160	135,7	160	299	255	188	160/180	285	G 1/2	G 2	G 1/2	13	8xM8	172	215	320	350	40	15
	180	135,7					192							240					
	200	140,4					212							250					
	225	140,4					237							275					
22	200	168,5	200	364	320	244	200/225	350	G 3/4	G 2 1/2	G 3/4	13	8xM8	214	265	390	420	46	15
	225	168,5					239							290					
	250	175,7					264							315					
	280	175,7					294							345					
	300	175,7					310							345					
28	250	213,2	250	424	380	302	250/280	450	G 3/4	G 2 1/2	G 3/4	13	8xM8	266	325	510	540	55	20
	280	213,2					296							355					
	300	218,5					316							375					
	315	218,5					331							390					
	335	218,5					351							410					

dimensions in millimetres/dimensions not shown see page 9

1) bore for dowel pin

- d<sub>4</sub> = earthing device or plug Pg 7
- d<sub>5</sub> = oil inlet (oil circulation or recirculating pump)
- d<sub>6</sub> = provision for thermometer G 1/2
- d<sub>7</sub> = oil sight glass or oil outlet (oil circulation)
- d<sub>8</sub> = plug (connection for heater, oil sump thermometer, water cooler)
- t = depth of thermometer bore
- \*\* = oil drain plug for size 22 and 28: G 3/4

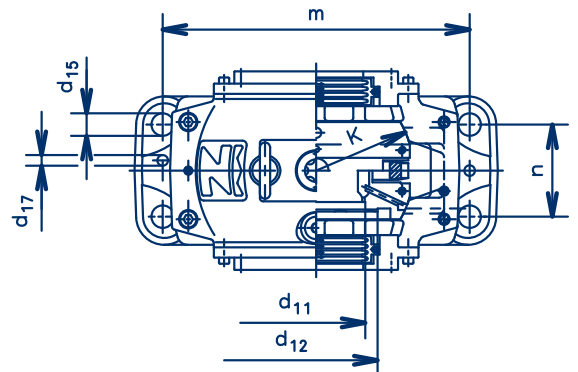
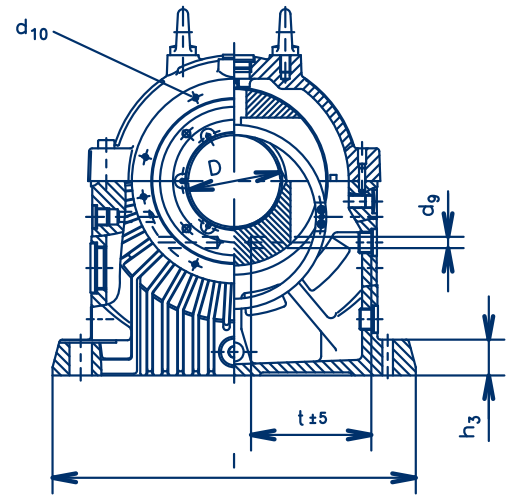
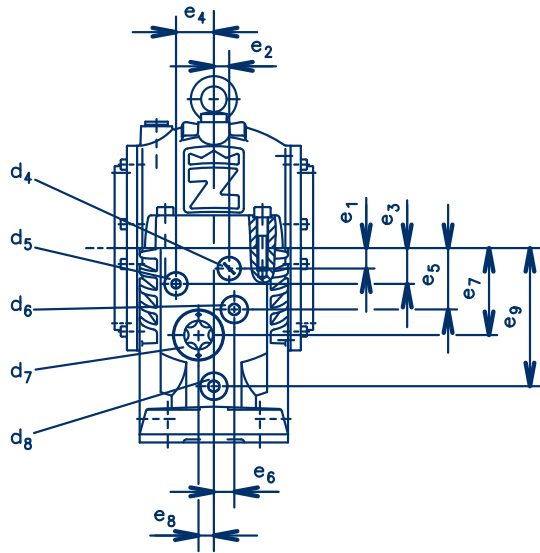

e1	e2	e3	e4	e5	e6	e7	e8	e9	h1	h2	h3	h4	l	m	n	t	dia. ø K	weight appr. kg	oil content appr. l
20	15	35	37	60	20	85	15	135	190	123	35	23	355	300	90	117,5 117,5 117,5	190	45	1,8
35	15	40	42	70	22,5	100	20	145	225	141	50	24	450	375	100	138 138 128	212	70	3
30	27,5	60	55	85	27,5	125	27,5	180	265	168	60	29	540	450	125	168 168 146 134	280	135	4,5
30	30	70	68	105	30	155	30	215	315	208	70	29	660	560	150	209 209 188 163	335	240	8
35	35	80	83	135	40	175	40	245	375	254	80	37	800	670	200	259 259 243 201 179	425	430	16,5
45	45	95	106	155	50	220	50	310	450	320	90	42	950	800	250	323 323 273,5 268,5 243,5	530	780	27,5

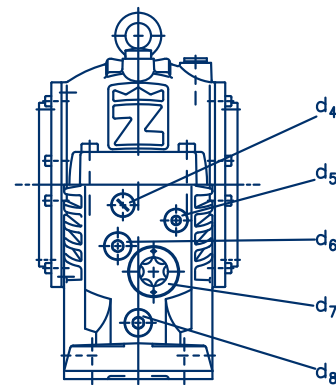
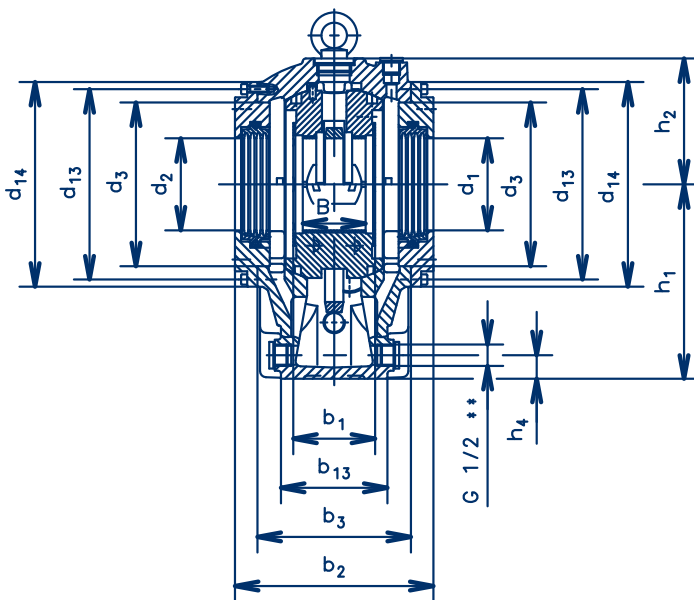

### Example for the nomination of a bearing

**Z R N L K 9 - 90**

- Z** Zoller plain bearing
- R** pedestal bearing, finned
- N** natural cooled and self contained
- L** plain cylindrical bore with loose oil ring
- K** thrust bearing with tapered land faces
- 9** size 9
- 90** shaft diameter 90 mm

#### 1 Type

Z = ZOLLERN plain bearing

#### 2 Housing

R = pedestal bearing, finned

#### 3 Heat dissipation\*

N = natural cooled, self contained  
Z = lubrication by oil circulation with extern. oil cooling  
W = water cooler in the oil sump

#### 4 Type of lubrication\*

L = plain cylindrical bore with loose oil ring

#### 5 Thrust part\*

B = plain white metal lined shoulders with oil grooves  
K = tapered land faced for both sense of rotation  
Q = without thrust capability

#### 6 Size

size 9

#### 7 Shaft diameter

90 mm

\* Special designs and technical informations are available upon request.

# DIMENSIONS OF SHAFT ZR

Size	D <sup>1)</sup>	b <sub>20</sub> <sup>2)</sup> (± 0,1)	b <sub>21</sub> <sup>3)</sup>	b <sub>22</sub>	b <sub>23</sub> <sup>4)</sup>	b <sub>24</sub> <sup>5)</sup>	d <sub>30</sub>	d <sub>31</sub> <sup>(e8)</sup>					d <sub>33</sub>	R <sub>1</sub> <sup>6)</sup>	R <sub>2</sub> <sup>6)</sup>	R <sub>3</sub>		
								d <sub>32</sub>										
9	80	80,4	90	100	5	50	110	80	90	100	110	90	2,5	4	1,6			
	120							80	80	90	100					100	100	110
	130							80	80	90	100					100	100	110
11	100	100,4	110	120	6	50	135	100	110	125	140	110	2,5	4	1,6			
	150							100	100	110	125					140	140	
	160							100	100	110	125					140	140	
14	125	125,4	140	150	8,5	60	170	125	140	160	180	140	4	6	2,5			
	190							125	125	140	160					160	160	
	200							125	125	140	160					160	160	
	220							125	125	140	160					160	160	
18	160	160,4	180	190	10	60	215	160	180	200	225	180	4	6	2,5			
	240							160	160	180	200					200	200	
	250							160	160	180	200					200	200	
	275							160	160	180	200					200	200	
	275							160	160	180	200					200	200	
22	200	200,4	220	240	13,5	70	265	200	225	250	280	300	225	6	10	4		
	290							200	200	225	250	250					250	
	315							200	200	225	250	250					250	
	345							200	200	225	250	250					250	
	345							200	200	225	250	250					250	
	345							200	200	225	250	250					250	
28	250	250,4	280	300	19	70	325	250	280	315	355	280	6	10	6			
	355							250	280	315	355					355	355	
	375							250	280	315	355					355	355	
	390							250	280	315	355					355	355	
	390							250	280	315	355					355	355	
	410							250	280	315	355					355	355	

1) Limit dimensions of the shaft acc. DIN 31 698, form and positional tolerances and surface roughness acc. DIN 31 699.

2) Standard thrust clearance is 0,5 mm. If reversible thrust loads or shock loads occur, dimension b<sub>20</sub> can be reduced by 0,2 mm. If a locating bearing (shell type B,K) is needed only for test runs, dimension b<sub>20</sub> can be enlarged by 4 up to 6 mm.

3) If the non-locating bearing has to allow larger motions (due to heat expansion or to large thrust clearances caused by the unit), dimension b<sub>21</sub> can be enlarged.

4) The plunge cut d<sub>32</sub> is dropped, if it is equal or smaller as the shaft diameter D.

5) The dimension b<sub>24</sub> is valid for a bearing with a floating labyrinth seal.

6) The radii R<sub>1</sub> and R<sub>2</sub> can be replaced by a plunge cut acc. DIN 509.

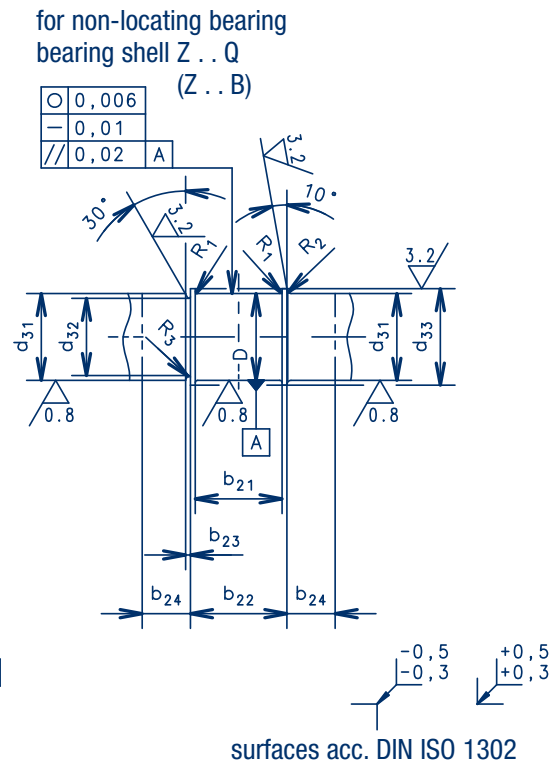
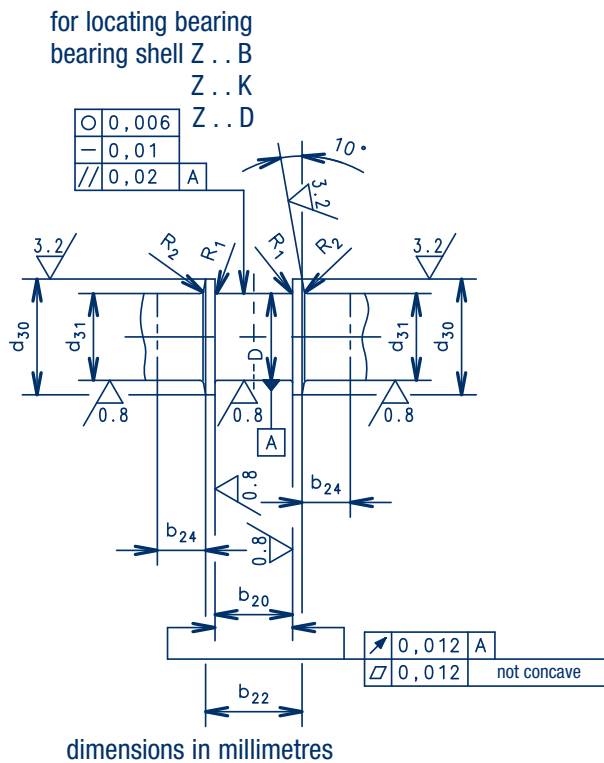



# DIMENSIONS OF SEALS ZR/ZF/ZM

Size	D	b <sub>27</sub>	b <sub>28</sub>	b <sub>29</sub>	b <sub>30</sub>	b <sub>31</sub>	b <sub>32</sub>	d <sub>3</sub>	d <sub>14</sub>	d <sub>36</sub>	d <sub>37</sub>	d <sub>38</sub>	d <sub>39</sub>	d <sub>40</sub>
7	60 70 80 90	21	31	21	12	8	21,5	130	170	135	135	128	135	135
9	80 90 100 110	29	39	27	14	8	21,5	160	200	160	160	158	160	160
11	100 110 125 140	31	41	27	16	8	21,5	190	230	190	190	188	160 — 190	160 — 190
14	125 140 160 180	33	43	27	18	8	21,5 — 26,5	240	280	240	240	238	190 — 240	190 — 240
18	160 180 200 225	36	46	27	21	10	26,5	285	350	295	295	282	240 — 295	240 — 295
22	200 225 250 280 300	39	49	27	24	10	26,5 — 31,5	350	420	365	365	347	295 — 365	295 — 365
28	250 280 315 355	42	52	27	27	10	31,5	450	540	480	365 — 480	447	365 — 480	365 — 460

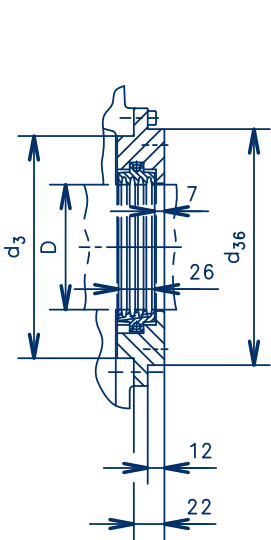

**Floating labyrinth seal**  
(protection IP 44)

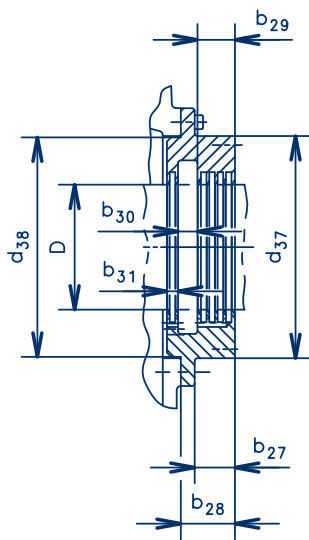

**Rigid seal\***  
(protection IP 44)

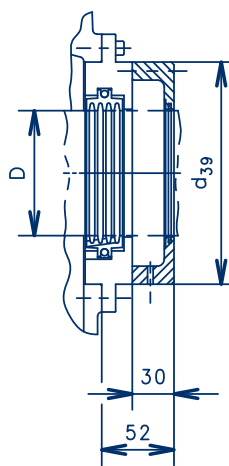

**Floating labyrinth seal with bolt-on baffle**  
(protection IP 55)

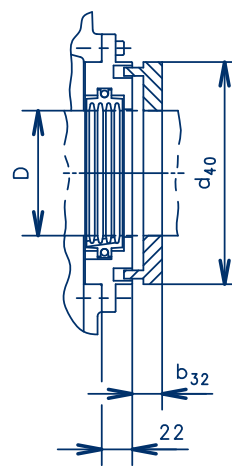

**Floating labyrinth seal with dust flinger**  
(protection IP 54)

max. axial movement of the dust flinger ± 6,5 mm (meets NEMA spec.)

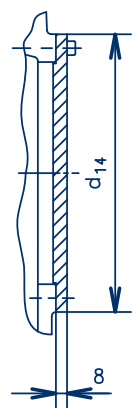

**End cover**

\* can be combined with a bolt-on baffle (IP 55) or a dust flinger (IP 54) too.

# DIMENSIONS ZF

Size	D (H7)	B	b1	b2	b3	b4	b5	b6	b7	nom. size d1 seal (optional)	d2	d3	d5	d7	d9	d10	d11	d12	d13	d14	d15
7	60	50	60	130	108	50	12	31	12	60/70 80/90	80	130	G 1/4	G 1	8	6xM6	66	86	150	170	11
	70	50															76	96			
	80	50															86	106			
9	80	61,4	80	162	140	70	14	22	12	80/90 100/110	100	160	G 3/8	G 1 1/2	11	8xM6	86	110	180	200	14
	90	61,4															96	120			
	100	65															106	130			
11	100	81,4	100	187	165	80	15	26	17	100/110 125/140	125	190	G 3/8	G 1 1/2	11	8xM6	108	135	210	230	14
	110	81,4															118	150			
	125	85															133	160			
14	125	105,4	125	227	205	100	16	26	23	125/140 160/180	160	240	G 1/2	G 2	11	8xM6	135	170	260	280	18
	140	105,4															150	190			
	160	106,4															170	200			
	180	106,4															190	220			
18	160	135,7	160	265	243	116	18	31	25	160/180 220/225	200	285	G 1/2	G 2	13	8xM8	172	215	320	350	22
	180	135,7															192	240			
	200	140,4															212	250			
	225	140,4															237	275			
	225																250	275			
22	200	168,5	200	336	314	150	20	32	37	200/225 250/280 300	250	350	G 3/4	G 2 1/2	13	8xM8	214	265	390	420	26
	225	168,5															239	290			
	250	175,7															264	315			
	280	175,7															294	345			
	300	175,7															310	345			
28	250	213,2	250	387	365	170	24	43	42	250/280 315/355	315	450	G 3/4	G 2 1/2	13	8xM8	266	325	510	540	33
	280	213,2									296						355				
	300	218,5									316						375				
	315	218,5									331						390				
	335	218,5									351						410				

dimensions in millimetres/dimensions not shown see page 9

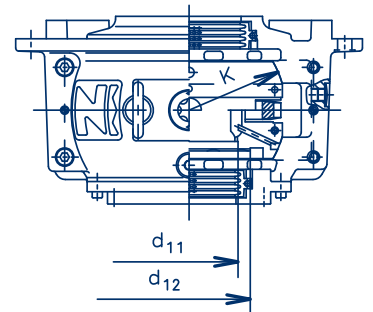
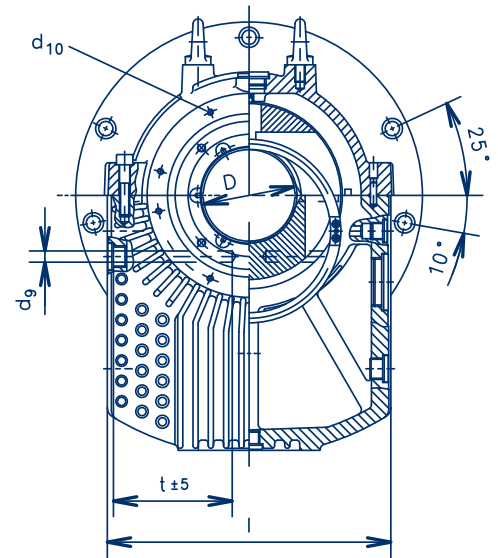
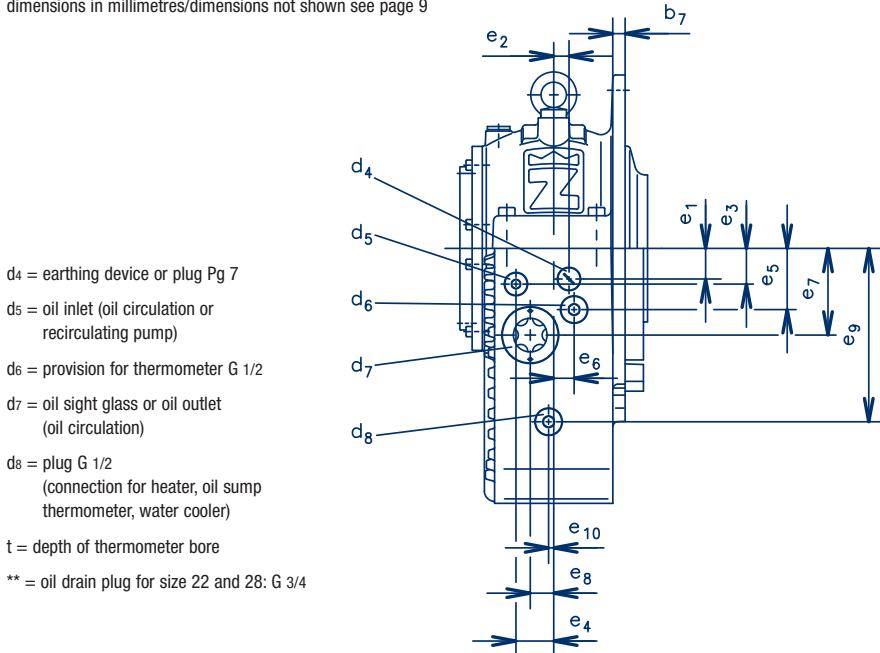

d16	d18	d19	d20 (h8)	e1	e2	e3	e4	e5	e6	e7	e8	e9	e10	h1	h2	l	t	dia. ø K	weight appr. kg	oil content appr. l
M10	235	260	210	19	0	25	25	45	15	70	22	125	5	180	100	200	90 90 80	140	27	1,2
M12	310	340	280	30	15	35	37	60	20	85	23	170	5	250	121	278	116,5 116,5 116,5	190	46	2,8
M12	350	380	315	30	17,5	40	42	70	22,5	100	30	180	8	280	141	320	137 137 127	212	74	4,7
M 16	415	460	355	30	27,5	60	55	85	27,5	125	27,5	240	9,5	340	173	370	162 162 140 128	280	125	8,5
M20	490	540	400	30	30	70	68	105	30	155	30	270	5	400	212	440	192 192 171 146	335	200	13,5
M24	620	680	500	35	35	80	83	135	40	175	40	350	15	450	262	550	247 247 231 177 155	425	430	24,5
M30	770	850	600	45	45	95	106	155	50	230	50	400	15	500	328	690	317 317 267,5 262,5 237,5	530	770	35,5

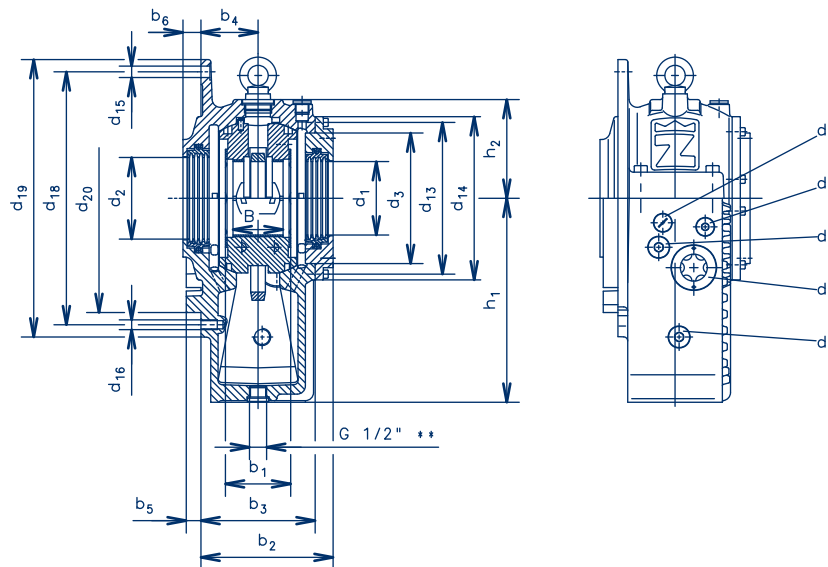

**Example for the nomination of a bearing**

**Z F N L K 9 - 90**

- Z** Zollern plain bearing
- F** end flange bearing, finned
- N** natural cooled and self contained
- L** plain cylindrical bore with loose oil ring
- K** thrust bearing with tapered land faces
- 9** size 9
- 90** shaft diameter 90 mm

- 1 Type** Z = ZOLLERN plain bearing
- 2 Housing** F = end flange bearing, finned
- 3 Heat dissipation\*** N = natural cooled, self contained  
Z = lubrication by oil circulation with extern. oil cooling  
W = water cooler in the oil sump
- 4 Type of lubrication\*** L = plain cylindrical bore with loose oil ring
- 5 Thrust part\*** B = plain white metal lined shoulders with oil grooves  
K = tapered land faced for both sense of rotation  
Q = without thrust capability
- 6 Size** size 9
- 7 Shaft diameter** 90 mm

\* Special designs and technical informations are available upon request.

# DIMENSIONS OF SHAFT ZF

Size	D <sup>1)</sup>	b <sub>20</sub> <sup>2)</sup> (± 0,1)	b <sub>21</sub> <sup>3)</sup>	b <sub>22</sub>	b <sub>23</sub> <sup>4)</sup>	b <sub>24</sub> <sup>5)</sup>	b <sub>25</sub>	b <sub>26</sub>	d <sub>30</sub>	d <sub>31</sub> <sup>(e8)</sup>				d <sub>33</sub>	d <sub>34</sub> (e8)	d <sub>35</sub> <sup>(e8)</sup>	R <sub>1</sub> <sup>7)</sup>	R <sub>2</sub> <sup>7)</sup>	R <sub>3</sub>	
										d <sub>32</sub>										
7	60	60,4	67	75	3	51,5	51,5	94	86 90 106	60	70	80	90	70 80 90	80	90 100 110	2	2	1,5	
	70									64	74	84								
	80																			
9	80	80,4	90	100	5	50	50	106	110 120 130	80	90	100	110	90 100 110	100	110 120 130	2,5	4	1,6	
	90									80	90	100								
	100																			
11	100	100,4	110	120	6	50	55	113	135 150 160	100	110	125	140	110 125 140	125	135 150 160	2,5	4	1,6	
	110									100	110	125								
	125																			
14	125	125,4	140	150	8,5	60	60	123	170 190 200 220	125	140	160	180	140 160 180 200	160	170 190 200 200	4	6	2,5	
	140									125	140	160								
	160																			
	180																			
18	160	160,4	180	188	10	60	65	127	215 240 250 275	160	180	200	225	180 200 225 250	200	215 240 250 250	4	6	2,5	
	180									160	180	200								
	200																			
	225																			
22	200	200,4	220	240	13,5	70	70	140	265 290 315 345 345	200	225	250	280	300	225 250 280 315 335	250	265 290 315 315 315	6	10	4
	225									200	225	250								
	250																			
	280																			
	300																			
28	250	250,4	280	296	19	70	75	139	325 355 375 390 410	250	280	315	355	280 300 315 335 355	315	325 355 375 390 395	6	10	6	
	280									250	280	315								
	300																			
	315																			
	335																			

1) Limit dimensions of the shaft acc. DIN 31 698, form and positional tolerances and surface roughness acc. DIN 31 699.

2) Standard thrust clearance is 0,5 mm. If reversible thrust loads or shock loads occur, dimension b<sub>20</sub> can be reduced by 0,2 mm. If a locating bearing (shell type B,K) is needed only for test runs, dimension b<sub>20</sub> can be enlarged by 4 up to 6 mm.

3) If the non-locating bearing has to allow larger motions (due to heat expansion or to large thrust clearances caused by the unit), dimension b<sub>21</sub> can be enlarged.

4) The plunge cut d<sub>32</sub> is dropped, if it is equal or smaller as the shaft diameter D.

5) The dimension b<sub>24</sub> is valid for a bearing with a floating labyrinth seal.

6) The dia. d<sub>35</sub> can be combined with every shell dia. D within one size.

7) The radii R<sub>1</sub> and R<sub>2</sub> can be replaced by a plunge cut acc. DIN 509.

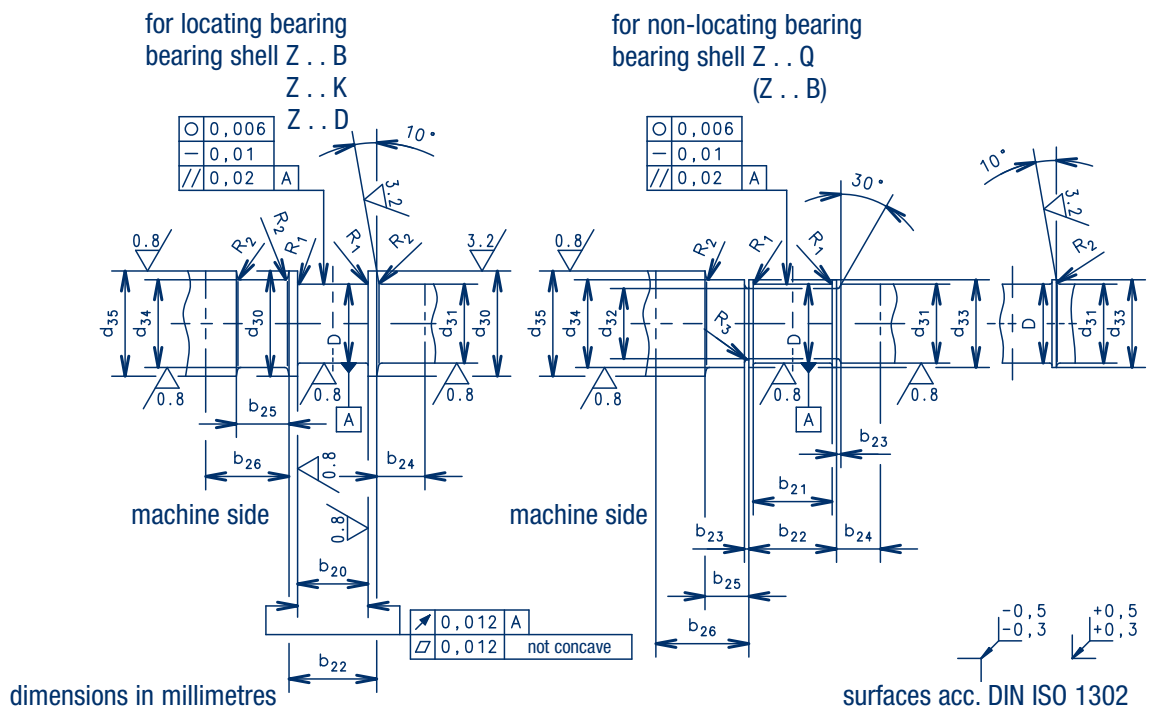

# MACHINE SEALS ZF

Size	b33	b34	b35	b36 <sup>8)</sup>	b37	d18	d20	d41 <sup>9)</sup> (optional)	d42	d43	d44	d45	d46	weight appr. kg
7	60	25	10	16	123	235	210	91,5 101,5 111,5	135	265	280	6,6	11	3,5 3,4 3,3
9	60	35	10	24	151	310	280	111,5 121,5 131,5	180	360	380	6,6	14	10,5 10,0 9,5
11	65	35	10	26	168	350	315	136,5 151,5 161,5	210	400	420	6,6	14	12,6 11,7 11,1
14	70	35	10	26	193	–	355	171,5 191,5 201,5 221,5	250	375	390	6,6	–	12,6 11,1 10,3 9,5
18	75	40	10	28	216	–	400	216,5 241,5 251,5 276,5	310	430	455	9	–	18,7 16,1 15,0 14,0
22	80	40	10	28	255	–	500	266,5 291,5 316,5 346,5 346,5	375	535	570	9	–	24,5 21,3 17,8 16,1 16,1
28	85	50	10	30	282	–	600	326,5 356,5 376,5 391,5 396,5	440	640	680	9	–	43,0 37,2 33,0 30,0 29,0

8) Min. thickness of the machine shield.

9) In order to allow the assembly of the machine seal, the inner dia. d41 must be larger as the dia. of the shaft collar d30 of the locating bearing.

The job of the machine seal is to protect the inner floating labyrinth seal against any interference from inside of the machine (negative pressure or strong air circulation).

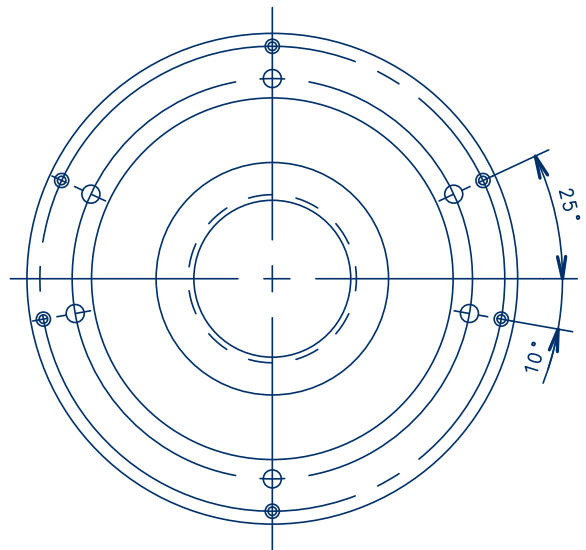
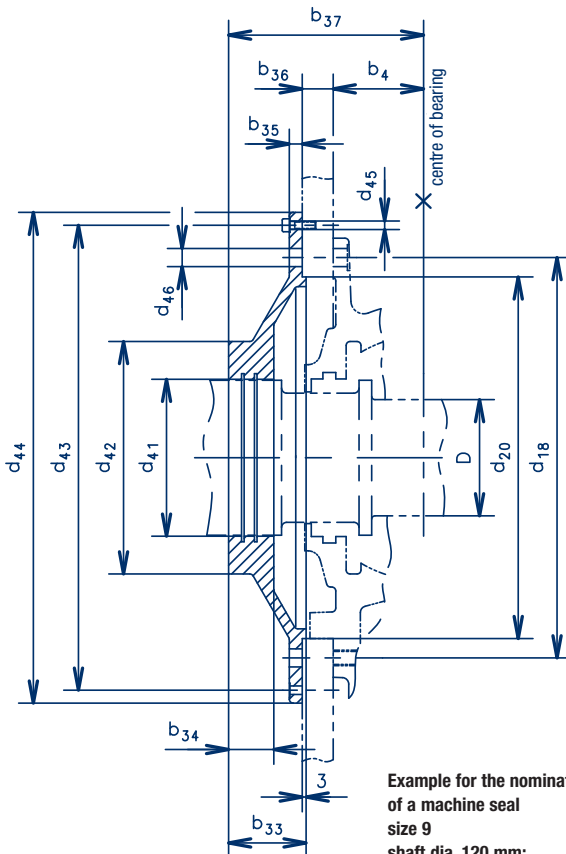

Example for the nomination of a machine seal size 9 shaft dia. 120 mm: ZF 9-120

dimensions in millimetres

Material: GG 25

# DIMENSIONS ZM

Size	D (H7)	B	b1	b2	b3	b4	b5	b6	b13 — b7	b8	b10	b11	b12	nom. size d1 seal (optional)	d2	d5	d7	d10	d11	d12	d13	d15	d16	d18
7	60	50	60	101	79	20	15	22	15 10	5	59	115	25	60/70 90/90	80	G 1/4	G 1	6xM6	66	86	150	11	M6	250
	70	50																	76	96				
	80	50																	86	106				
9	80	61,4	80	122	100	20	30	20	16	5	80	145	35	80/90 100/110	100	G 3/8	G 1 1/4	8xM6	86	110	180	11	M6	285
	90	61,4																	96	120				
	100	65																	106	130				
11	100	81,4	100	137	115	20	30	20	18	5	95	160	35	100/110 125/140	125	G 3/8	G 1 1/4	8xM6	108	135	210	14	M6	340
	110	81,4																	118	150				
	125	85																	133	160				
14	125	105,4	125	159,9	137,5	25	30	22,5	20	5	112,5	185	35	125/140 160/180	160	G 3/8	G 1 1/2	8xM6	135	170	260	18	M6	400
	140	105,4																	150	190				
	160	106,4																	170	200				
	180	106,4																	190	220				
18	160	135,7	160	179,5	157,5	25	30	17,5	25	6	132,5	210	40	160/180 200/225	200	G 1/2	G 1 1/2	8xM8	172	215	320	22	M8	475
	180	135,7																	192	240				
	200	140,4																	212	250				
	225	140,4																	237	275				
22	200	168,5	200	219,5	197,5	30	30	17,5	30	8	167,5	245	40	200/225 250/280 300	250	G 3/4	G 2	8xM8	214	265	390	26	M10	600
	225	168,5																	239	290				
	250	175,7																	264	315				
	280	175,7																	294	345				
	300	175,7																	310	345				
28	250	213,2	250	264,5	242,5	30	35	12,5	30	8	212,5	300	40	250/280 315/355	315	G 3/4	G 2 1/2	8xM8	266	325	510	33	M12	765
	280	213,2													296				355					
	300	218,5													316				375					
	315	218,5													331				390					
	335	218,5													351				410					

dimensions in millimetres/dimensions not shown see page 9

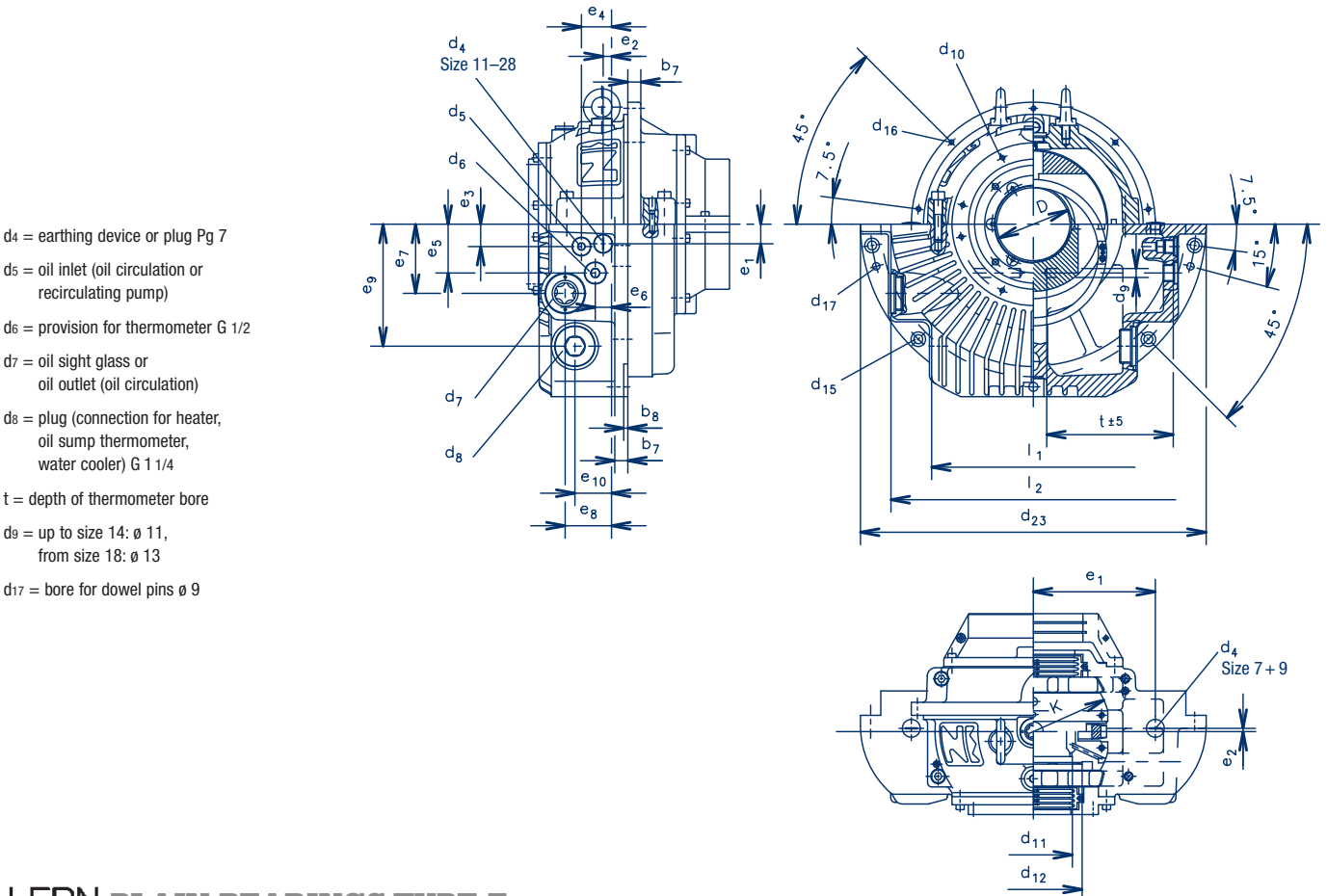

d19	d20 (h8)	d21	d22	d23	d24	d25	d26	e1	e2	e3	e4	e5	e6	e7	e8	e9	e10	h1	h2	h1	l2	t (±5)	dia. Ø K	weight appr. kg	oil content appr. l
265	300	325	235	350	90 100 110	135	G 1/4	19	4	24	25	45	15	70	48	125	30	175	105	206	280	132 132 122	140	45	1,2
300	375	400	270	425	110 120 130	160	G 3/8	150	16	27,5	37	60	20	85	65	150	45	212	126	250	350	155,5 155,5 155,5	190	62	2,8
355	450	475	320	500	135 150 160	190	G 1/2	25	18	40	42	70	22,5	100	65	175	55	250	146	300	409	186 186 176	312	98	4,9
425	530	560	380	600	170 190 200 220	250	G 1/2	30	27,5	60	55	85	27,5	125	70	215	70	300	175	355	492	227 227 205 193	280	155	7,8
500	630	670	450	710	215 240 250 275	300	G 1/2	30	30	70	68	105	30	155	80	260	80	355	212	425	572	264 264 243 218	335	250	12
630	800	850	570	900	265 290 315 345 345	390	G 3/4	35	35	80	83	135	40	175	100	330	100	450	263	530	736	347 347 331 291 269	425	445	30
800	1000	1060	730	1120	325 355 375 390 395	420	G 3/4	45	45	95	106	155	50	230	130	385	130	560	335	670	918	438 438 388,5 383,5 358,5	530	880	54,5

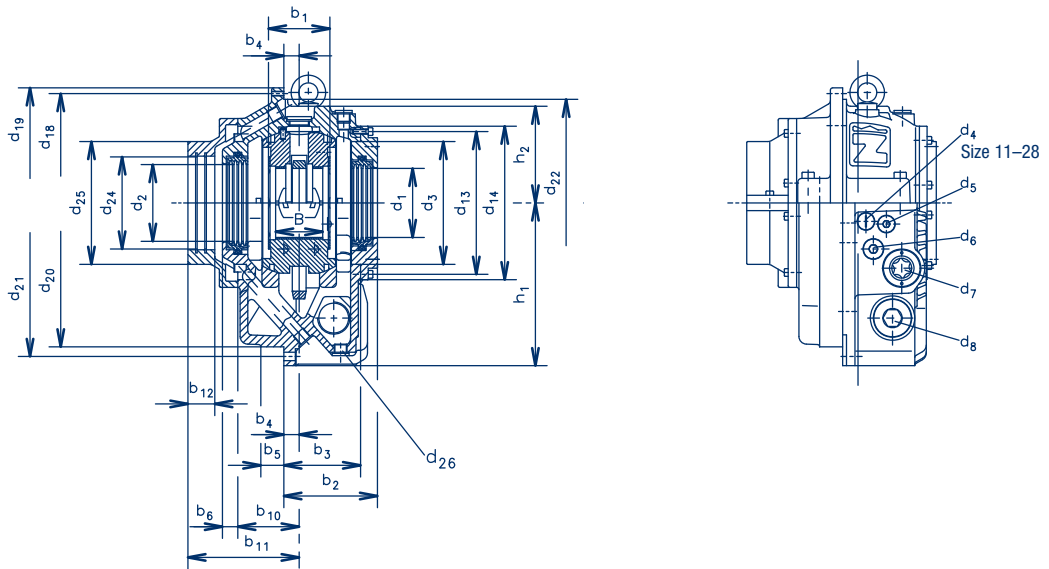

**Example for the nomination of a bearing**

**Z M N L K 9 - 90**

- Z** Zollern plain bearing
- M** center flange bearing
- N** natural cooled and self contained
- L** plain cylindrical bore with loose oil ring
- K** thrust bearing with tapered land faces
- 9** size 9
- 90** shaft diameter 90 mm

- 1 Type** Z = ZOLLERN plain bearing
- 2 Housing** M = center flange bearing
- 3 Heat dissipation\*** N = natural cooled, self contained  
Z = lubrication by oil circulation with extern. oil cooling  
W = water cooler in the oil sump
- 4 Type of lubrication\*** L = plain cylindrical bore with loose oil ring
- 5 Thrust part\*** B = plain white metal lined shoulders with oil grooves  
K = tapered land faced for both sense of rotation  
Q = without thrust capability
- 6 Size** size 9
- 7 Shaft diameter** 90 mm

\* Special designs and technical informations are available upon request.

# DIMENSIONS OF SHAFT ZM

Size	D <sup>1)</sup>	b <sub>20</sub> <sup>2)</sup> (± 0,1)	b <sub>21</sub> <sup>3)</sup>	b <sub>22</sub>	b <sub>23</sub> <sup>4)</sup>	b <sub>24</sub> <sup>5)</sup>	b <sub>25</sub>	b <sub>26</sub>	d <sub>30</sub>	d <sub>31</sub> <sup>(e8)</sup>				d <sub>33</sub>	d <sub>34</sub> <sup>(e8)</sup>	d <sub>35</sub> <sup>6)</sup> (e8)	R <sub>1</sub> <sup>7)</sup>	R <sub>2</sub> <sup>7)</sup>	R <sub>3</sub>		
										d <sub>32</sub>											
7	60	60,4	67	75	3	51,5	51,5	85,5	86	60	70	80	90	70	80	90	2	2	1,5		
	70									64	74	84	80							100	110
	80									80	90	100	110							120	130
9	80	80,4	90	100	5	55	60	95	110	80	90	100	110	90	100	110	2,5	4	1,6		
	90									80	90	100	100							120	130
	100									80	90	100	110							120	130
11	100	100,4	110	120	6	60	65	105	135	100	110	125	140	110	125	135	2,5	4	1,6		
	110									100	110	125	125							150	160
	125									100	110	125	140							160	160
14	125	125,4	140	150	8,5	65	75	115	170	125	140	160	180	140	160	170	4	6	2,5		
	140									125	125	140	160							180	200
	160									125	125	140	160							180	200
	180									125	125	140	160							180	200
18	160	160,4	180	190	10	65	75	120	215	160	180	200	225	180	200	215	4	6	2,5		
	180									160	160	180	200							225	250
	200									160	160	180	200							225	250
	225									160	160	180	200							225	250
	250									160	160	180	200							225	250
22	200	200,4	220	240	13,5	75	80	130	265	200	225	250	280	225	250	265	6	10	4		
	225									200	200	225	250							280	315
	250									200	200	225	250							280	315
	280									200	200	225	250							280	315
	300									200	200	225	250							280	315
28	250	250,4	280	300	19	90	90	155	325	250	280	315	355	280	315	325	6	10	6		
	280									250	250	280	315							355	390
	300									250	250	280	315							355	390
	315									250	250	280	315							355	390
	335									250	250	280	315							355	390
	375									250	250	280	315							355	390

- 1) Limit dimensions of the shaft acc. DIN 31 698, form and positional tolerances and surface roughness acc. DIN 31 699.
- 2) Standard thrust clearance is 0,5 mm. If reversible thrust loads or shock loads occur, dimension b<sub>20</sub> can be reduced by 0,2 mm. If a locating bearing (shell type B,K) is needed only for test runs, dimension b<sub>20</sub> can be enlarged by 4 up to 6 mm.

- 3) If the non-locating bearing has to allow larger motions (due to heat expansion or to large thrust clearances caused by the unit), dimension b<sub>21</sub> can be enlarged.
- 4) The plunge cut d<sub>32</sub> is dropped, if it is equal or smaller as the shaft diameter D.
- 5) The dimension b<sub>24</sub> is valid for a bearing with a floating labyrinth seal.
- 6) The dia. d<sub>35</sub> can be combined with every shell dia. D within one size.
- 7) The radii R<sub>1</sub> and R<sub>2</sub> can be replaced by a plunge cut acc. DIN 509.

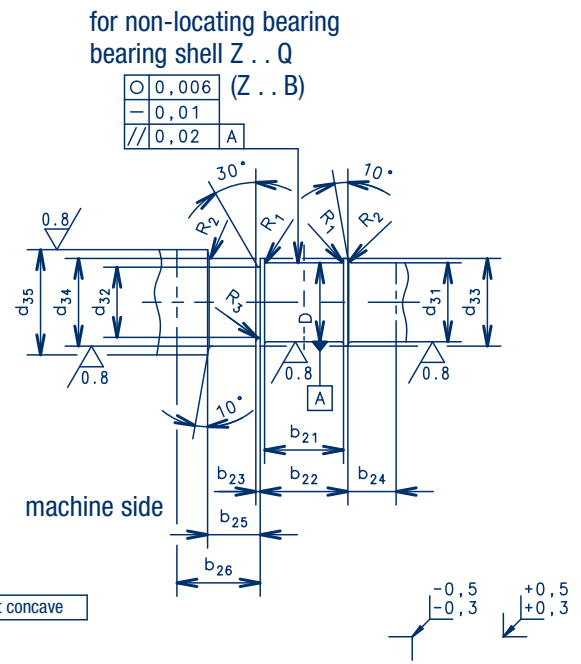
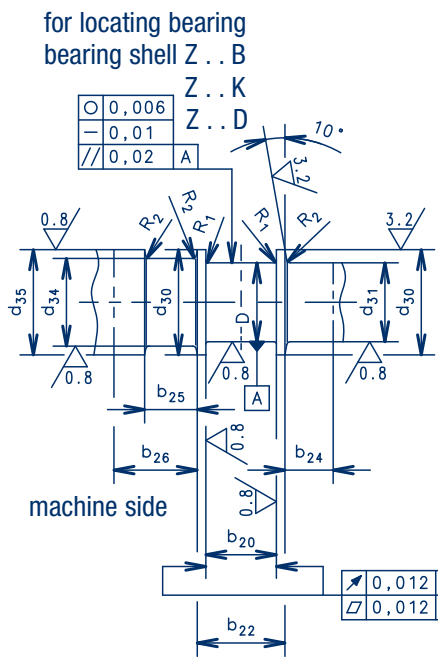



# DIMENSIONS ZR/ZF/ZM

Version Z...A

Size	D (H7)	d <sub>50</sub>	d <sub>51</sub>	d <sub>52</sub>	ZD titing pads number per side
9	80	132	110	20	14
	90	142	120	20	16
	100	143	125	16	20
11	100	157	135	20	16
	110	162	140	20	18
	125	168	150	16	22
14	125	192	165	25	18
	140	207	180	25	20
	160	217	195	20	24
18	160	244	210	31,5	18
	180	264	230	31,5	20
	200	273	245	25	24
22	200	308	265	40	18
	225	328	285	40	20
	250	339	305	31,5	24
	280	348	320	25	32
28	250	378	325	50	18
	280	408	355	50	20
	300	408	365	40	24
	315	-	-	-	-
	335	-	-	-	-

dimensions in millimetres

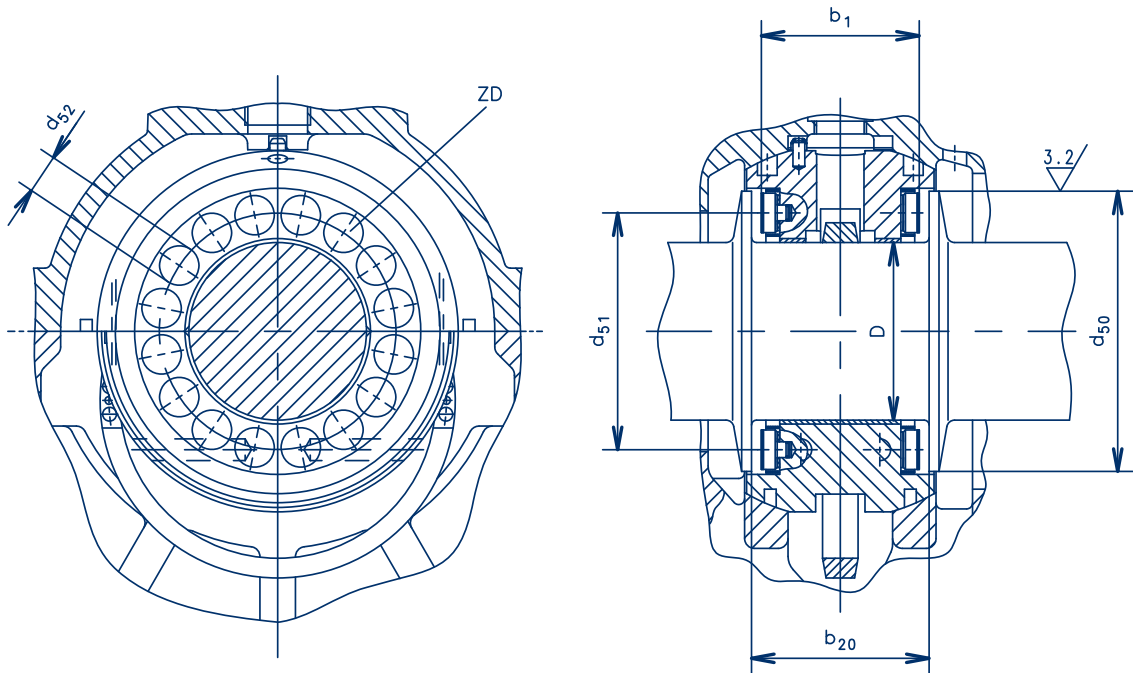

## Plants of the Zollern group of companies

	<p><b>Lauchertal plant</b> <b>ZOLLERN GmbH &amp; Co. KG</b></p> <p><b>Steel Profiles</b> Postfach 12 20 D-72481 Sigmaringen Tel. +49 75 71 70 24 6 Fax +49 75 71 70 27 5 eMail zst@zollern.de</p> <p><b>Foundry Technology</b> Postfach 12 20 D-72481 Sigmaringen Tel. +49 75 71 70 44 0 Fax +49 75 71 70 60 1 eMail zgt@zollern.de</p>	<p><b>France plant</b> <b>ZOLLERN TLC SAS</b></p> <p><b>Plain Bearing Technology</b> 62, Rue Pierre Curie B.P.No 1055 F-78131 Les Mureaux CEDEX Tel. +33 1 34 74 39 00 Fax +33 1 34 74 28 52 eMail infoTLC@zollern.com www.zollern.fr</p> 
	<p><b>Portugal plant</b> <b>ZOLLERN &amp; Comandita</b></p> <p><b>Foundry Technology</b> Rua Jorge Ferreirinha, 1095 Apartado 1027 P-4470-314 Vermoim MAIA Tel. +351 22 94 14 68 1 Fax +351 22 94 14 69 5 eMail zcp@zollern.pt</p>	<p><b>Sweden plant</b> <b>ZOLLERN Norden AB</b></p> <p>P. O. Box 233 SE-73224 Arboga Tel. +46 58 91 60 35 Fax +46 58 91 20 02 eMail info@zollern.se www.zollern.se</p> 
	<p><b>China plant</b> <b>ZOLLERN (Tianjin) Machinery Co., LTD.</b></p> <p><b>Transmission Technology</b> No. 79, 11th Avenue TEDA 300 457 Tianjin Peoples Republic of CHINA Tel. +86 22 25 32 38 11 Fax +86 22 25 32 38 10 eMail sales@zollern.sina.net</p>	<p><b>USA plant</b> <b>ZOLLERN North America L.P.</b></p> <p>283 Lockhaven Drive Suite 204 Houston TX 77073 USA Tel. +1 71 36 73 79 02 Fax +1 71 36 73 79 50 eMail zollernna@aol.com</p> 
	<p><b>Dorsten plant</b> <b>ZOLLERN Dorstener Antriebstechnik GmbH &amp; Co. KG</b></p> <p><b>Transmission Technology Gears</b> Hüttenstraße 1 D-46284 Dorsten Tel. +49 23 62 67 0 Fax +49 23 62 67 40 3 eMail zda@zollern.de</p>	<p><b>Romania plant</b> <b>S.C. Zollern S.R.L.</b></p> <p>0317235 Pecica FN Ferma 20 Arad - Romania</p>
	<p><b>Braunschweig plant</b> <b>ZOLLERN BHW Gleitlager GmbH &amp; Co. KG</b></p> <p><b>Plain Bearing Technology</b> Postfach 32 13 D-38022 Braunschweig Tel. +49 53 12 60 50 Fax +49 53 12 60 53 00 eMail bhw@zollern.de</p>	<p><b>Sales offices</b></p> <p><b>France</b>      <b>ZOLLERN S.à.r.l.</b> 13, Rue Allwies F-57200 Sarreguemines Tel. +33 3 87 95 35 14      eMail zollernsarl@wanadoo.fr Fax +33 3 87 95 35 21      www.zollern.fr</p> <p><b>Great Britain</b>      <b>Zollern UK Limited</b> Castle Hill Kenilworth GB-CV8 1NB Tel. +44 19 26 51 54 20      eMail sales@zollern.co.uk Fax +44 19 26 85 34 11      www.zollern.co.uk</p> <p><b>Italy</b>      <b>ZOLLERN Italiana S.r.L.</b> Via della Ciocca, 9 I-21026 Gavirate (VA) Tel. +39 03 32 46 20 59      eMail info@zollern.it Fax +39 03 32 46 20 67      www.zollern.it</p> <p><b>Netherlands</b>      <b>ZOLLERN Nederland B.V.</b> Postbus 134 NL-5150 AC DRUNEN Tel. +31 41 63 22 92 0      eMail zollern@zollern.nl Fax +31 41 63 20 93 6      www.zollern.nl</p> <p><b>Russia</b>      <b>ZOLLERN Ltd.</b> 115114, Russia, Moscow Derbenevskaja nab., 11, A Sector 2, Office 66</p>
	<p><b>Osterode plant</b> <b>ZOLLERN BHW Gleitlager GmbH &amp; Co. KG</b></p> <p><b>Plain Bearing Technology</b> Rolandsweg 16-20 D-37520 Osterode am Harz Tel. +49 55 22 31 27 0 Fax +49 55 22 31 27 99 eMail bhw@zollern.de</p>	
	<p><b>Brazil plant</b> <b>ZOLLERN Transmissoes Mecanicas LTDA</b></p> <p><b>Plain Bearing Technology</b> Av. Manoel Inácio Peixoto, 2147 BR-36771-000 Cataguases MG Tel. +55 32 34 29 53 02 Fax +55 32 34 29 53 26 eMail zollern@zollern.com.br</p>	
	<p><b>Aulendorf plant</b> <b>ZOLLERN Maschinenbauelemente GmbH &amp; Co. KG</b></p> <p><b>Mechanical Engineering Components</b> Postfach 12 65 D-88322 Aulendorf Tel. +49 75 25 94 81 30 Fax +49 75 25 94 81 00 eMail zmb@zollern.de</p>	
	<p><b>Soest plant</b> <b>ZOLLERN Aluminium-Feinguss Soest GmbH &amp; Co. KG</b></p> <p><b>Foundry Technology</b> Overweg 15 D-59494 Soest Tel. +49 2921 7896-0 Fax +49 2921 7896-17 www.zollern-afs.de info@zollern-afs.de</p>	

# CONTACT

## ZOLLERN GmbH & Co. KG

### Plain Bearing Technology

Heustraße 1  
D-88518 Herbertingen  
Tel. +49 75 86 95 95 20  
Fax +49 75 86 95 97 15  
eMail zlt@zollern.de



## ZOLLERN GmbH & Co. KG

### Transmission Technology

Heustraße 1  
D-88518 Herbertingen

### Automation Division

Tel. +49 75 86 95 95 86  
Fax +49 75 86 95 95 85  
eMail zht@zollern.de

### Gears and Winches Division

Tel. +49 75 86 95 95 47  
Fax +49 75 86 95 95 75  
eMail zat@zollern.de

### Herbertingen plant

We offer comprehensive project management:

- Many years of project experience
- CAD masters
- Project meetings on-site and plant inspections
- Detailed, binding offers



**ZOLLERN GmbH & Co. KG**

**Plain Bearing Technology**

Heustraße 1  
D-88518 Herbertingen  
Tel. +49 75 86 95 95 20  
Fax +49 75 86 95 97 15  
eMail [zlt@zollern.de](mailto:zlt@zollern.de)  
[www.zollern.com](http://www.zollern.com)

